

INOX | Upright Cabinets

REFRIGERATED CABINETS ▶ GN2/1-NO FROST ▶ CHILLER

GRCG 1850



		GAS R290	 70 mm	4 CLIMATIC CLASS	 38°C
	 LED				

DETAILS

Wheels for easy positioning	Lock fitted as standard	Evaporator with anti-corrosion treatment



GENERAL FEATURES

- GN2/1 Refrigerated upright cabinet (GLASS DOOR)
- Stainless Steel exterior and interior
- Ventilated Cooling
- Automatic compressor cycle defrost
- Evaporator and condenser with anti-corrosion treatment
- Foaming Agent Cyclopentane (70mm per side)
- Digital Thermostat
- Removable Gasket
- LED light and lock fitted as standard
- Door with self closing (Not reversible)
- Adjustable shelves GN2/1: N.12 Pcs
- N.6 Wheels for easy positioning
- Energy efficiency class: E

TECHNICAL SPECIFICATIONS

Capacity	1900 L
Temperature	+3°C - +10°C
Consumption	5.3 kWh/24h
Rated Power	945 W
Noise level	43 dB(A)
Net Weight	304 Kg
Gross Weight	323 Kg
External Dimensions (WxDxH mm)	2050x900x2075
Internal Dimensions (WxDxH mm)	1905x680x1560
Packaging dimensions (WxDxH mm)	2070x860x2170
Loading quantities 20'/40'/40'HQ	6/13/13

PRODUCT DIMENSIONS

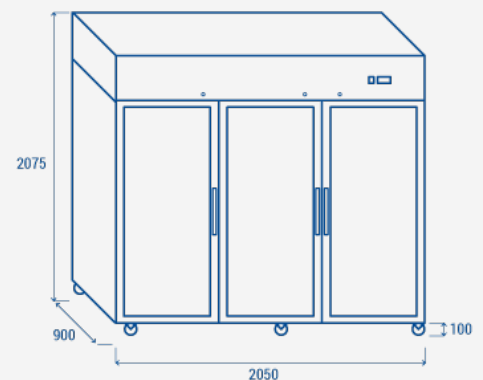

CERTIFICATION

